



# **BURLEY G4220 – 9 MODEL & G4230 - 9 FLUELESS GAS HEATER**

## **INSTALLATION, SERVICING & USER INSTRUCTIONS**

FOR USE IN THE COUNTRIES STATED ON THE DATA PLATE AND CARTON  
WITH NATURAL GAS G20  
OR LPG PROPANE GAS G31  
(REFER TO RATING LABEL)

**For the following countries: GB, IE**

**EVEN IF YOU HAVE FITTED THESE FIRES BEFORE,  
PLEASE FOLLOW THESE INSTRUCTIONS STEP BY STEP.**

*Legislation and regulations do change over time!*

### **LEAVE THESE INSTRUCTIONS WITH THE USER**

TO OBTAIN YOUR FIRST YEAR GUARANTEE, THE INSTALLER AND CUSTOMER  
MUST FILL IN THE SEPARATE GUARANTEE AND RETURN IT TO  
BURLEY WITHIN 7 DAYS OF FITTING.

A FREE SECOND YEAR GUARANTEE IS OFFERED SUBJECT TO THE FIRE BEING SERVICED  
BY A GAS SAFE™ REGISTERED ENGINEER (FORMERLY CORGI) DURING THE FIRST YEAR OF OWNERSHIP.  
PROOF OF SERVICING MUST BE RETAINED

**FAILURE TO HAVE THIS APPLIANCE FITTED BY A GAS SAFE™ REGISTERED  
INSTALLER (FORMERLY CORGI) INVALIDATES THE WARRANTY**

**Burley Appliances Ltd,**  
Lands End Way, Oakham, Rutland, LE15 6RB  
Telephone: +44 (0)1572 756956 Fax: +44 (0)1572 724390  
e-mail: [info@burley.co.uk](mailto:info@burley.co.uk) web: [www.burley.co.uk](http://www.burley.co.uk)

G4221InstUser  
G20/31  
Issue September 2014 – v.6

## **INTRODUCTION**

Thank you for choosing this burley product. All of our products carry a CE mark which is awarded by an independent test house (notified body) and shows the fires have been type tested to meet the essential requirements of the European Gas Appliance Directive and the appropriate British Standards.

This is a highly efficient Flueless Live Fuel Effect Appliance. The burner system is very clean burning and a catalyst cleans the combustion products even further.

An oxygen depletion sensing pilot light is also fitted and will sense any significant oxygen depletion in the room and shut the fire down safely.

### **1. APPLIANCE DATA**

Refer to the appliance data badge (this is located beside the control knob) **ENSURE THAT THE LOCAL CONDITIONS OF USE CORRESPOND TO THE INFORMATION ON THE DATA BADGE.**

	<b>Natural Gas G20</b>	<b>LPG (Propane) G31</b>
<b>Category</b>	I2H	I3P
<b>Supply Pressure</b>	20mBar	37mBar
<b>Inlet Pressure</b>	20mBar *	37mBar
<b>Heat Input (Net)</b>	<b>(High)</b> 2.5kW <b>(Low)</b> 1.5kW	2.5kW (180g/h) 1.5kW (107g/h)
<b>Inlet Connection</b>	8mm Compression	8mm Compression
<b>Injector</b>	Elbow 180	Elbow 90

\*The inlet pressure must be **within +/- 1mBar** of specification (NG 20mbar & PR 37mbar) with **all** gas appliances in the house switched on **and also** with just the Burley heater operating. If outside of this tolerance the fault is most likely to be in the installation pipe work or service governor at the meter. If the problem is the meter governor, this is the property of the gas service provider (such as Transco / National Grid 0800 111999 or Bord Gais) and they should be called to rectify this. The fire will not operate correctly if the pressures are incorrect.

### **2. GENERAL REQUIREMENTS**

1. Gas appliances must be installed in accordance with the rules in force. In the UK it is the law that all gas appliances must be installed by a Gas Safe™ registered installer (formerly CORGI), in accordance with the Gas Safety (Installation and Use) Regulations (as amended). The installation must be in accordance with the relevant parts of local and national building regulations. For the Republic of Ireland, reference should be made to IS813, ICP3, and guidance from Bord Gais, building regulations and any other rules in force.  
**Failure to have the fire fitted by a qualified person nullifies ALL guarantees.**
2. The area in which the fire is installed must have at least 100cm<sup>2</sup> of permanent purpose provided ventilation. For Republic of Ireland, 2 vents of not less than 60cm<sup>2</sup> must be provided at high and low level, with minimum vertical separation of 1.6m. Note wherever possible, to prevent draughts, these should be on the same wall.  
There must be a minimum of 1 metre distance between the fire and any air vent.  
Curtains must not obscure air vents.
3. **Floor vents, window vents and chimneys are NOT suitable forms of ventilation. Any purpose provided ventilation should be checked regularly to ensure it is free from obstruction**
4. In the event of a gas leakage, the gas supply must be turned off and advice sought.
5. Working surfaces include the air outlet grille, door and stove body.

6. The heater must not be used in a room area of less than 30m<sup>3</sup> in volume. To convert cubic feet (ft<sup>3</sup>) to cubic metre (m<sup>3</sup>) divide the room volume in cubic feet by 35.3. Adjoining spaces, not separated by a door may be combined.
7. The heater must not be used on or against a combustible surface.
8. No furniture, soft furnishings, decorations, wall coverings or curtains must be within 1 metre of the appliance and its convection outlets.
9. The heater must not be installed in high rise flats or basements.
10. Do not install this appliance in:
  - a) A bathroom, shower room or in a room used or intended to be used as sleeping accommodation. Sleeping areas must be separated from the appliance by a door.
  - b) In a cupboard or compartment within such a room; or
  - c) In a cupboard, compartment or space adjacent to such a room if there is an air vent from the cupboard, compartment or space into such a room.
11. When the heater is not to be used for a time, ensure the gas control or adjacent isolators are turned off.
12. Using this appliance as a sole heat source can lead to condensation problems in periods of cold weather and heavy use. Always ensure that the room has a background heat source such as central heating or storage heaters.
13. The fire must not be run with its door open or with cracked, incorrectly fitted or missing glass.
14. The guard on the appliance is to prevent risk of fire or injury from burns and no part of it may be permanently removed. It does not give full protection for young children, the elderly or infirm. Parts of the appliance get hot, an additional guard to BS6539 or BS6778 must be used in the presence of children, the elderly and infirm.
15. This is not a drying appliance. Do not place clothing or other articles, on or against it.
16. On no account must air inlets under the stove or outlet grills (see diagram page 4) be obstructed.
17. Do not store or use flammable substances on or near the heater.
18. Do not spray aerosols on or near the heater when it is working.
19. Do not use whilst painting & decorating, or in newly decorated rooms as the residues can lead to unpleasant smells from the appliance. Always cover or have the appliance removed when decorating.
20. Houses with warm air heating systems, solid walls, or no damp proof course may be unsuitable for this appliance. (Consult your supplier)
21. **Asbestos is not contained within any part of this appliance.**
22. This is a Flueless appliance and **MUST NOT** be fitted into a working flue. Where an old fireplace opening is to be used then the flue must be sealed off from the fire. A specific installation method exists
- 18 The heater must not be used in rooms where the atmosphere is likely to contain water or chemical vapours which may adversely affect the appliance or its finish.
- 19 If any material, such as plastic, melts onto the surface of the glass, turn the heater **off** and **allow it to cool. Do not remove the material when hot.** A proprietary ceramic hob cleaner such as 'hob brite' can be used to clean the glass. Only clean the appliance when cold.

- 1 LIGHTING PROCEDURE.** Identify the control valve fitted to the appliance and follow the appropriate instructions.

**MANUAL CONTROL**

There are 2 control knobs on the appliance. The right hand one controls On/Off and pilot/main burner. The left hand one is the comfort level thermostat which turns the fire down once the indicated temperature is reached. If during use the pilot is alight but the main burner is not lit, check the thermostat position and if necessary select a warmer setting. The range of the thermostat is around 13°C – 45°C.

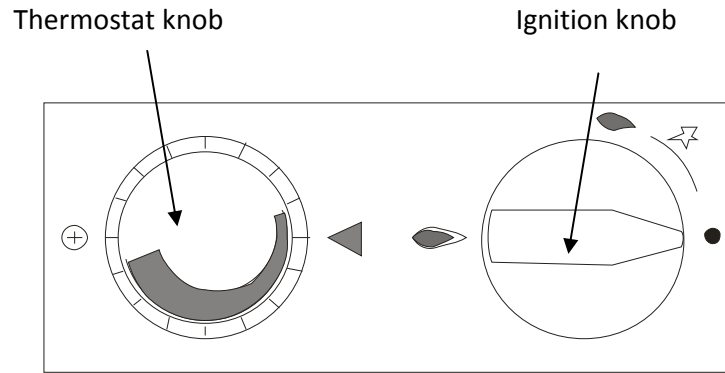

- 1.1.** To light the fire, first ensure the right hand control (Ignition) knob is turned clockwise to OFF, and then press the knob for several seconds then turn slowly anticlockwise to the ignition position. A click will be heard and the pilot (under right side of fuel bed) should light. If it does not, repeat the operation a few times to purge any air in the pipe. Continue to hold knob for 15 – 20 seconds to establish the pilot and then release. If the pilot fails to establish, turn off, wait 1 minute then repeat lighting procedure. It is not unusual for the pilot to stay alight only after the second or third attempt. Once the pilot has been established rotate the knob counter clockwise towards the larger flame symbol to light the main burner. If no gas comes through to the main burner, rotate the left hand knob (thermostat) to a hotter room setting and the fire will light.

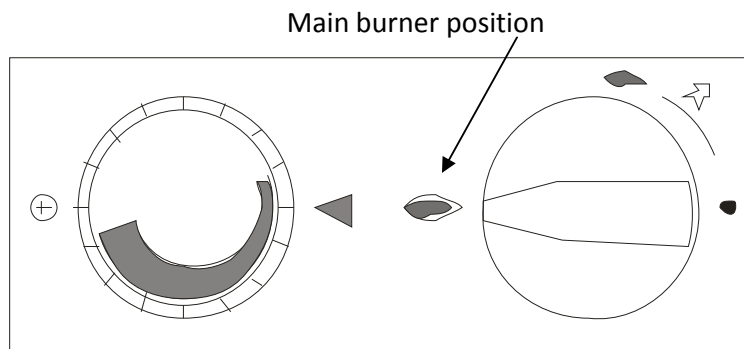
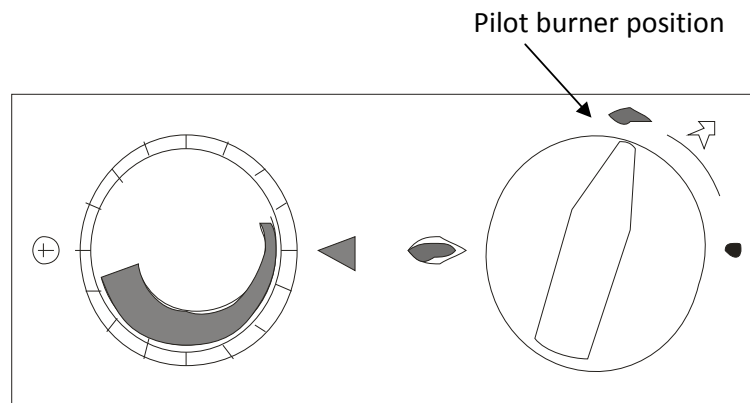

Main burner operational & thermostatically controlled

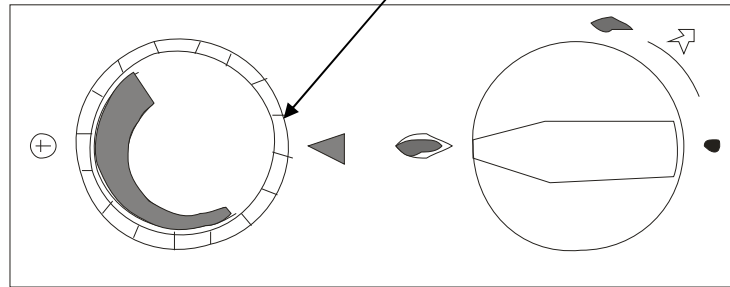

1.2. To turn the fire off, rotate the right-hand knob fully clockwise back to its OFF position.

### 1.3. SLIDE CONTROL

1. Press the control lever to the right of its travel and listen for the spark generator clicking which should light the pilot.
2. Continue to hold down for a further 10 seconds.
3. If the pilot fails to stay alight, slide the control lever to the limit of its travel (off) & wait for 3 minutes & repeat the process.
4. Once the pilot is alight, position the control lever to the desired position.
5. To turn the fire off turn the control lever to the left of its travel.
6. The off position on the fire may not correspond exactly with the control lever. This is only intended as an indication.

### 1.4. Battery Replacement

Behind the ash pan cover, located towards the right of the burner is the spark generator which is fitted with the battery facing you. Flick out the battery from the right hand end of the battery holder and remove battery. Replace with a good quality 1.5v AA battery ensuring the polarity markings on the battery correspond with the markings on the battery holder. Check the spark generator clicks when the control linkage is depressed downwards.

### 1.5. Total Control

Ensure that the ON/OFF switch is in the ON position (-) & that the manual knob is also pointing downwards towards its ON position (see below).

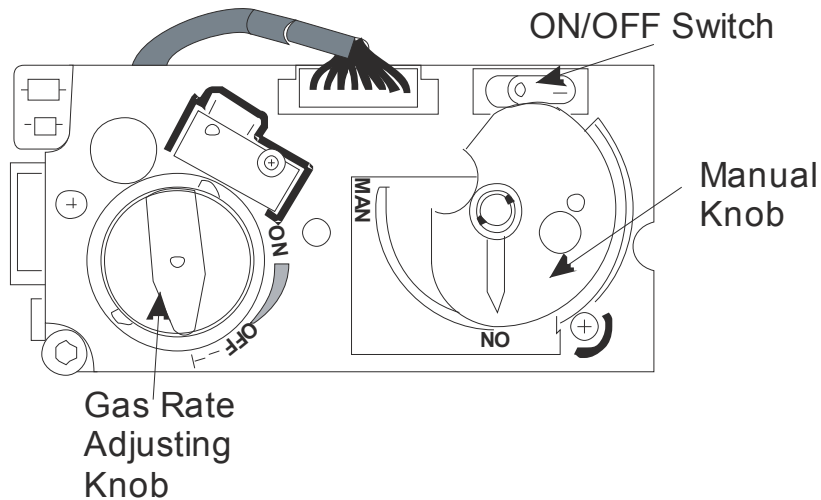

- 1.6. Simultaneously press and hold the ● (red circle) and 🔥 (large flame) buttons until an acoustic signal confirms the start sequence has begun, then release the buttons.

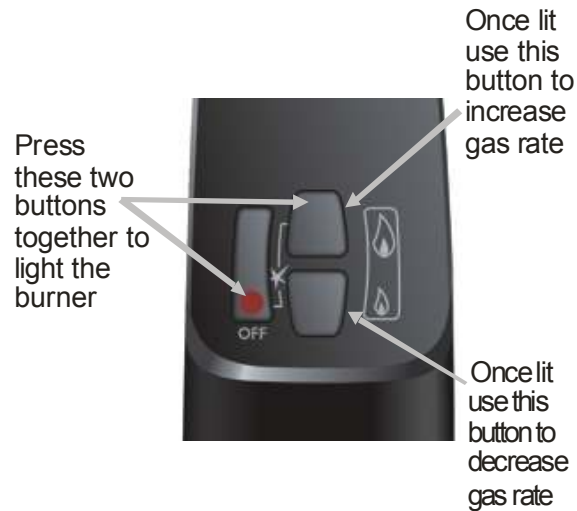

- 1.7. The acoustic signal should cease and be replaced with the ticking sound of the spark igniter. When the pilot flame is lit the igniter will stop & another acoustic signal will confirm the pilot has been established (if the pilot fails to establish repeat the process. Due to the safe & efficient nature of the fire it is not unusual for this to take two or even three attempts). The acoustic signal will now cease & the gas rate adjusting knob will automatically turn to its high setting.
- 1.8. To adjust the gas rate to desired setting press the 🔥 (large flame) to increase the flame height or 🔥 (small flame) to decrease the flame height on the handset.
- 1.9. To leave the fire in **standby mode** press the 🔥 (small flame) until the main burner goes out. The pilot should remain on in this mode & help to reduce condensation.
- 1.10. To turn the fire off completely (including the pilot) press the ● red OFF button on the handset.

## **Battery Replacement**

### ***Handset***

- 1.11. On the back of the handset remove the battery cover by pressing down the top of the cover & sliding it down. Remove & unclip the old battery & replace with a new PP3 9 volt battery.

### ***Receiver Unit (located under burner)***

Remove the heat shield surrounding the unit. Pull the receiver unit out from underneath the burner & remove the top cover. Remove old batteries & replace with four new AA batteries ensuring the polarities are correct. Replace the battery cover & return the receiver unit to its original position. REPLACE THE HEAT SHIELD over the unit.



**CAUTION:** With the exception of battery replacement, the battery holder must be located within the heat shield **at all times**.

## **Programming Handset to Receiver**

If for some reason the remote handset requires re-programming to operate the receiver follow the procedure below:

1. Press and hold using a pointed object the receiver's reset button until you hear two acoustic signals.
2. After the second longer acoustic signal, release the reset button and within the subsequent 20 seconds, press the  (small flame) on the remote handset until you hear an additional long acoustic signal confirming the new code is set.

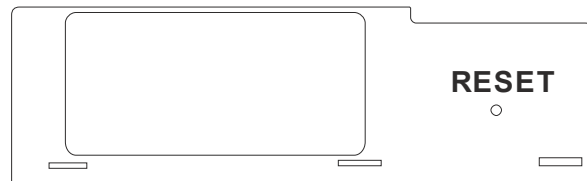

## 2 **WARNINGS**

- 1 **Read the instructions before using this appliance.**
- 2 **This appliance requires installation by a competent qualified person.**
- 3 **Use only in a correctly sized and ventilated area.**
- 4 **Once the coals have been positioned in accordance with the installation instructions, they must not be moved except for servicing.**
- 5 **The surfaces of the appliance become very hot during use.**
- 6 **Before cleaning or maintenance switch fire OFF and allow to cool.**
- 7 **Any purpose provided ventilation should be checked regularly to ensure it is free from obstruction.**

**Overall Dimensions**

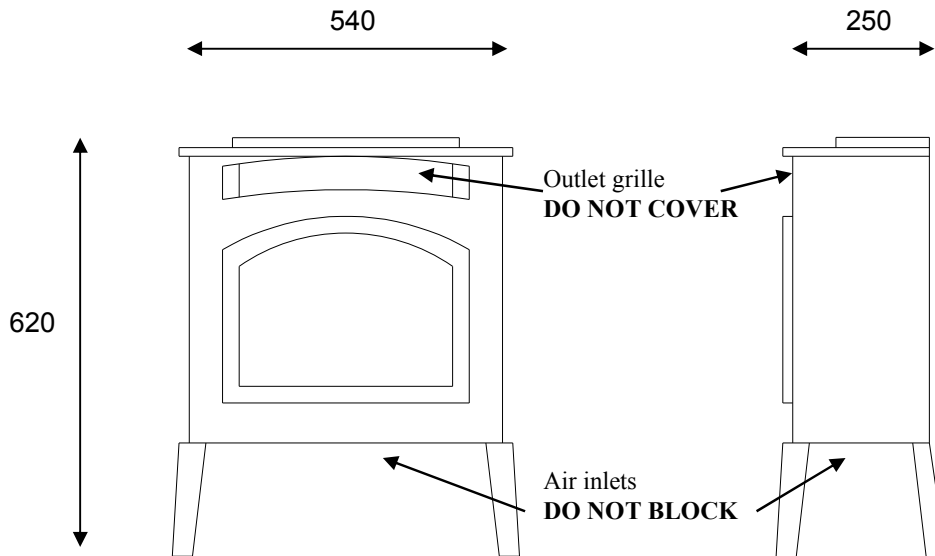

## 3 **Hearths, floor protection and carpets**

This appliance does not need a hearth and can be used on wooden, laminate floors and non-combustible surfaces. It must not be placed directly onto carpets or rugs. Where the floor is carpeted, the carpet must finish 100mm clear of the appliance legs and be fully removed underneath. Loose rugs should be kept well away from the appliance (warn the customer of this). Standing the appliance directly on a floor can lead to discolouration and / or drying out.

When a hearth is used, the top surface can be wood but be aware that heat can discolour certain finishes over a period of time and can dry out poorly seasoned wood causing splitting. The hearth should be 100mm larger than the appliance all round and minimum 12mm thick. Carpets can come to the edge of the hearth.

## 4 **Clearance to Walls**

**Rear Clearance** - The rear of the appliance can be installed directly against a non combustible wall. A distance of 50mm should be allowed to walls with wooden cladding, wallpaper, or finishes likely to be affected by heat.

**Side Clearance** - The sides of the appliance can be installed with 25mm of side clearance to non combustible materials but this should be increased to 150mm for combustibles.

The fireplace and ALL materials including paints or lacquers must be rated for a minimum constant temperature of 150°C. Any hearth or back panel not meeting the above clearance dimensions must be made from a non-combustible material such as marble or slate, although 'lightweight' and tiled surrounds can be used provided they have a minimum heat rating of 150°C.



**Top Clearance** - The heat from the appliance is concentrated towards the front edge directly above the combustion products outlet. The clearances stated relate to a distance from the back edge of the stove.

A non combustible shelf may be fitted to within 50mm of the top edge of the fire. Combustible material such as wood may be fitted to within 100mm of the sides of the firebox provided it protrudes no further forward than 100mm.

Maximum depth of shelf	100mm	150mm	200mm
Minimum distance from top of fire to underside of shelf	200mm	250mm	300mm

These distances should be doubled if the shelf is above the outlet grille.

## **5 Gas Supply**

The gas supply should be installed in accordance with all regulations in force. Consideration should be given to the routing to conceal from view and avoid potential damage. Pipes through walls should be sleeved. The gas connection is 8mm compression and should be made in semi-rigid tubing such as copper pipe. Before working on pipe work plug open ends. A servicing isolator is supplied with the appliance and this should be used to permit disconnection for servicing etc.

All gas work should be undertaken by a competent person, see General Requirements.

## **6 Siting the Appliance**

If the appliance is to be in or in front of an open fireplace, the chimney or flue MUST be blocked off to prevent the draw from disrupting the flame pattern of the fire which can lead to poor combustion or sooting. Extractor fans must be sited at least 2m from the appliance.

Check the room has sufficient volume and ventilation; if these requirements cannot be met then the appliance should not be installed. Consideration should be given to the requirements of other appliances working in the same room space. If other flueless appliances such as cookers are in the same room then consideration should be given to the combined room size requirement.

Check the room has a background heat source such as central heating radiators, storage heaters etc. Check the appliance data plate details are correct for the kind of gas used and the country of installation.

Carry out any building works such as in-gle-nooks, hearths and recesses. If no hearth is being used, remove any carpets to required clearance. Lay in the gas supply and leave a tail to connect to.

Position the appliance and ensure it is stable and unlikely to move in normal use. Some hearths can be slippery and it is best to fix the appliance by removing the plugs in the plastic feet and screwing down. Care should be taken to ensure correct clearances around the stove.

Before connecting any pipes to the appliance, fully purge pipes of any debris or swarf etc.

Attach the gas connection to the stove and carry out a leak test in an approved manner.

## 7 Laying the Coals G4220 - 4229 range

Opening the hinged door on the appliance (which is secured by a 10mm nut) gains access to the ceramics. On no account should the appliance be operated whilst the door is open except for brief periods during maintenance.

Do not lay the ceramics in any way other than that shown.

### **Fitting back coal**

Take the ceramic back block and place into position as shown. The coal shapes should be facing you and the base of the coal locates behind the tags on the burner.



### **Fitting front Coal**

The front coal fits vertically between the burner and the front of the case as shown.

The coal sits with the 4 coal shapes uppermost and coal profile facing you. The feet on the front coal locate between the burner and tags in the burner tray.



## **Laying the Logs G4230 - 4239 range**

Do not lay the logs in any way other than that shown.

### **Fitting back log**

Take the ceramic back block and place into position as shown. The log shapes should be facing you and the base of the log locates behind the tags on the burner.



### **Fitting the Front Log**

The front Log fits vertically between the burner and the front of the case as shown.

The feet on the front log locate between the burner and tags in the burner tray.



- Always secure the door closed after laying the fuel effects.
- Do not attempt to use any unit with broken or damaged glass.
- Do not use the fire with broken coals or logs
- Do not add any additional fuel elements to the fire.
- Do not use similar looking parts from other appliances,
- Use only genuine spare parts.
- Do not use the appliance for burning waste.

## **8 Commissioning the Appliance**

If the pipes have not been purged of debris do it before lighting the appliance. Failure to do so will result in blockages within the burner and pilot.

Burley Appliances is the only company to bench run and thoroughly test every single gas fire it produces. Burley is in the unique position of knowing that every appliance that leaves the factory is in perfect working order.

The installer should measure the inlet pressure with the appliance running on high and ensure it is to specification.

Attach a manometer to the inlet test point and ensure there is a pressure of 20mb (+/- 1mb) for natural gas appliances or 37mB for propane appliances.

Now turn on every other gas appliance in the house and re-check the pressure. The pressure must still be within the tolerance of +/- 1mb.

Turn off all other gas appliances and turn the fire down to pilot only, the pressure must still be within the tolerance of +/- 1mb. If it is over 21mbs the fire will not function correctly and the pilot may go out. If it is not TRANSCO or BORD GAIS must be called to adjust the regulator to the house before the fire can be commissioned further.

Any large pressure fluctuation indicates pipe work or governor problems and should be rectified. Instruct the customer on the operation of the appliance and leave all instructions with them.

**DUE TO THE SENSITIVE NATURE OF THE OXY PILOT, IT IS NOT UNUSUAL FOR THE PILOT TO EXTINGUISH UP TO/AFTER 1 MINUTE WHEN FIRST LIT. RELIGHT AND THE PILOT WILL STAY ALIGHT. THIS IS DUE TO THE MOIST GASES FORMED BY THE PILOT DROPPING DOWN AND SNUFFING IT AS WELL AS THE COLD METAL WORK. IT IS SAFE TO LEAVE THE PILOT ON 24 HOURS A DAY TO MAKE LIGHTING EASIER.**

## **9 Spark Failure**

The gap between the pilot electrode and the pilot should be 3.5 – 4.5mm and normally adjustment is not necessary. If the igniter fails a lighted taper can be inserted into the pilot area when attempting to light the pilot and this should help the fire to light.

## **10 Oxygen Depletion Pilot System**

There is a highly sensitive oxygen depletion sensor designed into the pilot light. If any part is damaged the entire unit must be replaced using only genuine spare parts as similar looking parts from other appliances may well give inferior performance. If the fire repeatedly trips off in operation the oxygen depletion system may be operating and a qualified engineer should investigate this.

## **11 Instructing the Customer**

The installer should instruct the customer on the operation of the appliance and handover all instruction leaflets.

The customer must be made aware of the need for regular servicing of the appliance; this will normally be once a year.

The customer should also be made aware that no rubbish should be thrown into the fire bed and that purpose provided ventilation should be checked regularly.

## **12 Servicing Instructions**

Before commencing any servicing, ensure that the gas is isolated and the appliance is cool.

Cleaning – The casing should be wiped with a cloth dampened in soapy water. The glass may be cleaned with any non-abrasive cleaner such as 'hob brite'.

The coals contain refractory fibre (RCF). Excessive exposure to these materials may cause temporary irritation to the eyes, skin and respiratory tract; consequently, it makes sense to take care when handling these parts to ensure that the release of dust is kept to a minimum. We recommend the use of a HEPA filtered vacuum to remove any dust and soot accumulated in the heater before and after working on it. When replacing these articles, they should not be broken up, but sealed in heavy duty polythene bags labelled 'RCF Waste', which may be disposed of at a tipping site licensed for industrial waste. Protective clothing is not required, but normal hygiene rules of no smoking, eating or drinking in the work area should be followed.

Controls – The system for monitoring the oxygen supply to the burner is not adjustable and must not be put out of operation. Should the oxy-pilot system need to be replaced, the original manufacturer's parts must be used.

Injectors – Only original manufacturer's injectors must be used.

The unit must be serviced at least once per year, preferably at the beginning of the heating season.

All servicing must be carried out by a qualified service person. A combustion analysis check should be carried out using an analyser to BS7967 and sampling the entire width of the combustion product outlet. Ratio of CO/CO<sub>2</sub> should be less than 0.002 within 30 minutes. (20ppm CO per 1% CO<sub>2</sub>) A reading of CO in the room centre should give a rise of less than 9ppm over ambient, peak reading.

Light the fire using the method in the instructions and ensure that the pilot lights consistently and the pilot flame envelopes the thermocouple evenly, it is located at the front on the right-hand side.

The pilot should hold in 6-10 seconds. Turn control to main burner, this should light smoothly.

Ensure the valve gives adequate turn down and the thermostat bulb reduces the burner rate to low when heated.

Run the appliance for 10 minutes, ensuring burner flames settle evenly.

The gas manifold pressures are factory pre-set using highly accurate equipment, and must not be altered.

The catalyst is unlikely to need replacement during the life of the heater. The appliance should be inspected before use and at least annually by an authorised service person. More frequent cleaning may be required due to accumulation of lint and dust from carpeting etc.

It is imperative that the control compartments, burners and circulating air passageways of the appliance be kept clean. Replacement parts are available from your local dealer.

Using unapproved accessories could prove hazardous and will invalidate the warranty.

Read the instructions before using this appliance.

This appliance requires installation and annual servicing by a Gas Safe™ registered installer (formerly CORGI).

Use only in a correctly sized and ventilated area.

Any purpose provided ventilation should be checked regularly to ensure it is free from obstruction.

Once the coals or logs have been positioned in accordance with the installation instructions, they must not be moved except for servicing.

The surfaces of the appliance become very hot during use.

Do not attempt to touch or wipe clean the fire whilst hot, doing so could result in severe burns or damage to the paintwork.

## NOTES

The first time that the appliance is used, there will be some odour produced due to the newness of the materials. It is recommended that the unit is fired at maximum setting for several hours and the room is kept ventilated during this period. It is usual for Flueless appliances to produce an initial odour after start up.

**DUE TO THE SENSITIVE NATURE OF THE OXY PILOT, IT IS NOT UNUSUAL FOR THE PILOT TO EXTINGUISH UP TO/AFTER 1 MINUTE WHEN FIRST LIT. RELIGHT AND THE PILOT WILL STAY ALIGHT. THIS IS DUE TO THE MOIST GASES FORMED BY THE PILOT DROPPING DOWN AND SNUFFING IT AS WELL AS THE COLD METAL WORK. IT IS SAFE TO LEAVE THE PILOT ON 24 HOURS A DAY TO MAKE LIGHTING EASIER.**

### **Cleaning the fuel effect**

Switch the appliance OFF and allow to cool before commencing. The fuels can be accessed by opening the hinged door on the appliance which is secured by a 10mm nut. On no account should the appliance be operated whilst the door is open.

Do not lay the coals in any way other than that shown in the Installation and Servicing Instructions.

- Do not use the fire with broken ceramics.
- Do not add any additional fuel elements to the fire.
- Do not use similar looking parts from other appliances, use only genuine spare parts.
- Do not use the appliance for burning waste.
- The fire must not be run with its door open or with cracked, incorrectly fitted or missing glass.
- On no account must air inlets under the stove or outlet grills (see diagram) be obstructed.

### **GENERAL**

To qualify for your free second year guarantee, you must fully complete and return the separate Guarantee Card. There are sections that your fitter must complete whilst fitting the fire. If the fully completed Guarantee Card is not returned within 7 days of fitting, the appliance is just covered by the standard 12-month guarantee.

As with all gas appliances, this fire **MUST** be serviced at least every 12 months, preferably at the start of the heating season. The second year guarantee is conditional on this service-taking place; a dated service receipt is proof of this. A qualified service engineer must carry out servicing.

*Due to our policy of continual improvement and development the exact accuracy of descriptions and illustrations can not be guaranteed.*

*Burley Appliances are the only company to bench run and thoroughly test every single Flueless gas fire it produces. Burley is in the unique position of knowing that every appliance leaves the factory in perfect working order.*

# Additional Servicing and Technical Information

## 1. Flue Gas Analysers – Installation & Servicing Facts

- Please read this sheet even if you have fitted our fires before.
- Please leave this sheet with the customer as reference for future servicing of the appliance.
- Please explain to the customer how the fire works and the details and facts listed on this sheet, particularly what the catalyst does and doesn't do.
- If you have any doubts about the test procedure please visit our website or call our technical help line

### Testing – Points to note...

- Before testing ensure that the room size is correct for the heat output of the fire. 30cu<sup>3</sup> for 2.5kw output, 40cu<sup>3</sup> for 3.5kw and 50cu<sup>3</sup> for 4.5kw.
- In all installations regardless of room size there must be an air vent positioned at least one metre from the fire at either high or low level through an outside wall providing 100cm<sup>2</sup> of free air. (For the Republic of Ireland 2 vents of not less than 60cm<sup>2</sup> must be provided at high and low level, with minimum vertical separation of 1.6m).
- The analyser used must be manufactured to BS7967 and the test must be carried out in accordance with BS5871 Pt 4
- The catalytic converter needs heat to work, therefore before you start testing; the fire must have been lit and burning on full for at least 15 mins.

There are two tests to carry out. A Co / CO<sup>2</sup> ratio test and a room centre CO test.

1. The first test is the CO / CO<sup>2</sup> ratio test and should be carried out at the fire exhaust vent, do not stick the probe of the analyser in through the grill but move the probe back and forth 1 inch in front of the outlet grill. (We use a piece of perforated 8mm pipe attached to the analyser with flexible rubber tube). You should record a ratio of no more than 0.002 % (20ppm CO to 1% Co<sup>2</sup>). It is advisable to have a high sample of CO as this will improve the test
2. The second test is the room centre CO test. You should stand in the room centre with the probe at waist height and read the level of CO; this should be no more than 9ppm over ambient peak. Please record these readings on the customers guarantee card.

Our Flueless fires also contain the following safety devices (an ODS (Oxygen Depletion Sensor) and FSD (Flame Supervision Device). Point out to the customer that unfortunately these are not found on all gas hobs; which are also flueless devices)

## **2. Points to Note Regarding the Catalytic Convertor!**

- If the customer smokes tobacco products, lives on a busy road or is cooking with a gas oven/hob at the time of testing you must ensure that an ambient CO reading is taken before lighting the fire and attempting a reading.
- *Does the catalytic convertor need replacing?* The catalytic convertor does not need replacing unless it has become physically broken or the combustion test shows deterioration in performance over time. To constantly test the performance of the catalytic converter, our laboratory has been running appliances eight hours per day, five days per week, for up to seven years. Periodically we send catalytic converters back to the manufacturer for testing. After the equivalent of 30 years of use, the catalytic converter is as efficient as it was when brand new. Burley manages to achieve this by designing the fire to ensure that the catalytic converter is in exactly the right position for long life and maximum efficiency. (For other makes of fire please consult the relevant manufacturer). Only use replacement catalyst supplied by Burley.
- If you or the customer detects any odours from the fire please remember that the catalytic convertor is not an air filter and does not remove smells. The ceramics in the fire can absorb household smells and in turn these smells get emitted when the fire is lit, especially if the fire is used in an enclosed space for a period of time. If this is the case we recommend that the fire is run on maximum for at least 5 hours with the doors and windows open. This should be done at least twice a year, preferably in the spring and autumn or at any time they notice a smell.
- We do not advise the burning of wax candles within 1 metre of the fire. Wax particles can become airborne and deposit and solidify in the fire causing potential combustion problems.
- The catalyst can also be affected by airborne paint smells and vapors from some plug in air fresheners. The fire must be removed or sealed if you plan to decorate anywhere in the house. If you can detect smells from the fire carry out the burning off procedure as above.

**Further information regarding the catalytic convertor and Flueless fires in general can be found on our website [www.burley.co.uk](http://www.burley.co.uk)**



### **3. Gas rating of Burley Flueless Appliances**

Burley's Flueless Gas Appliances are all gas input rated in the factory and undergo further line tests for combustion, sooting and visual performance. For Installers who wish to gas input rate appliances we need to establish tolerances for pass and fail.

#### **Manufacturers Tolerances**

The Heat Input on appliances can be expressed as either a Nett or a Gross figure. When the installer is gas rating from the meter they will be using gross heat input which is 10% higher than Nett. This conversion has to be taken into account if the manufacturer has quoted a nett figure.

The manufacturer also has to account for production tolerances on pipes, injectors, valves etc and is allowed a further +/-5% tolerance on the maximum rate.

#### **Burn Down**

Cold appliances generally allow a greater rate of gas to pass through them and once the appliance warms the gas density alters and causes the rate to reduce to the figure stated. This is known as Burn Down.

Manufacturers carrying out their technical tests allow appliances to be fully warm and burn down before taking readings and this is typically after 1 hour. Some appliance manufacturers quote a 'cold' figure for the gas rate so that installers can measure this immediately.

#### **Installer Tolerances**

It is important to take a gas rate test over a reasonable period of time so that the capacity of the meter is used. On low Input appliances such as our flueless this is even more critical because uncertainties can creep in. It is worth measuring over a 5 minute period to make sure.

It is also important to get your inlet pressure to 20mBar.

In a gas appliance factory compensation is also made for variations in

- % Saturation of Gas
- Variation in Calorific Value
- Variation in Gas Density
- Gas Temperature
- Gas Pressure
- Atmospheric Pressure
- Meter Calibration
- Stopwatch Calibration.

In the home it is not possible to correct for these therefore an uncertainty factor needs to be built into all measurements.

Currently Gas Safe™ (formerly CORGI) does not quote a figure on this uncertainty but the measured gas rate could vary by +/-5%.

#### **Conclusion**

In adding all the variables together,

- an appliance quoting Gross Heat Input could be anything from +/-10% of the quoted heat input
- an appliance quoting Nett Heat Input could be anything from 0% to +20% of the quoted figure when measured as a Gross figure.
- If the appliance is cold anything up to a further 10% error could be expected and we don't quote these figures because they change rapidly. The figures shown below are hot figures.

<b>Model</b>	<b>Heat Input Quoted</b>	<b>Minimum (Gross)</b>	<b>Maximum (Gross)</b>	<b>Cu Ft Per Hour</b>
<b>Environ, Esteem</b>	2.5kW Nett	2.5kW Gross	3.0kW Gross	8.49
<b>Ambience 4121</b>	3.5kW Nett	3.5kW Gross	4.2kW Gross	11.67
<b>Acumen 4111</b>	4.2kW Nett	4.2kW Gross	5.4kW Gross	14.85

#### **4. Burley Appliances Ltd - Domestic Guarantee Conditions?**

We pride ourselves on the quality of service we deliver to our customers and all Burley Appliances' products carry a fully inclusive 12-month parts and labour guarantee. This guarantee is extended by another 12 months free of charge provided that your appliance is registered with us within two weeks of installation and that it is serviced by a Gas Safe™ registered installer (formerly CORGI) at the end of the first year. What the guarantee cannot cover is problems caused by incorrect installation or servicing, or any work carried out by non- a Gas Safe™ registered installer (formerly CORGI).

We undertake that if within 12 months of the date of purchase, your fire or any part thereof is proved to be defective by reason of faulty workmanship or materials, we will at our discretion repair or replace the same free of any charge for labour, materials or carriage subject to condition that:

- All gas appliances are installed to the latest Gas Installation regulations by a qualified Gas Safe™ registered installer (formerly CORGI) and connected to the correct gas type and pressure as stated on the rating plate attached to the equipment.
- The fire is fitted in a room with the following minimum dimensions 2.5Kw = 30m<sup>3</sup> / 3.5Kw = 40m<sup>3</sup> / 4.2Kw = 50m<sup>3</sup>
- A wall vent is installed not less than 1 meter away from the fire allowing 100cm<sup>2</sup> of free air.
- You have the fire serviced by a Gas Safe™ registered installer (formerly CORGI) within the first year (as with all gas products, every gas appliances must be serviced every year).
- The appliance has not been subject to misuse, accident, or repaired or fitted by anyone other than a Gas Safe™ registered installer (formerly CORGI) or our own engineer.
- The appliance has been used solely for domestic purposes and is on domestic premises i.e. not for commercial or trade use.
- The appliance has been used solely in accordance with the instruction book.

Any in guarantee work carried out by Burley Appliances will be charged for if the fault is caused by incorrect pressure or gas, incorrect installation, operator error, neglect or abuse.

**All guarantee cover is instantly and permanently cancelled if a non Gas Safe™ registered installer (formerly CORGI) or person carries out any installation.**

#### **Exclusions**

This guarantee **does not** cover:

- Damage resulting from external transportation, improper use or neglect, the replacement of any light bulbs or removable parts of glass or plastic.
- Costs incurred for calls to put right an appliance, which is improperly installed.
- Appliances that are the subject of rental agreements.
- EC Countries - the standard guarantee is applicable but is subject to the owner's responsibility and cost, to ensure the appliance meets the standards set by the country to which the product is taken.

**Any appliance or defective part replaced shall become the Company's property**

**Service Calls are made between 09.30 am and 04.30 pm Monday - Friday.**

**This guarantee is in addition to your statutory and other legal rights.**

**Proof of purchase will be required as will be a copy of the a Gas Safe™ registered installer notice.**